



5 YEARS WARRANTY*

Register your Zeliox here for up to 5 years warranty

*5 years consist of statutory warranty plus additional warranty extension. Registration within 3 months required. Statutory warranty varies by country.

ECO S/I/II/III quick start guide

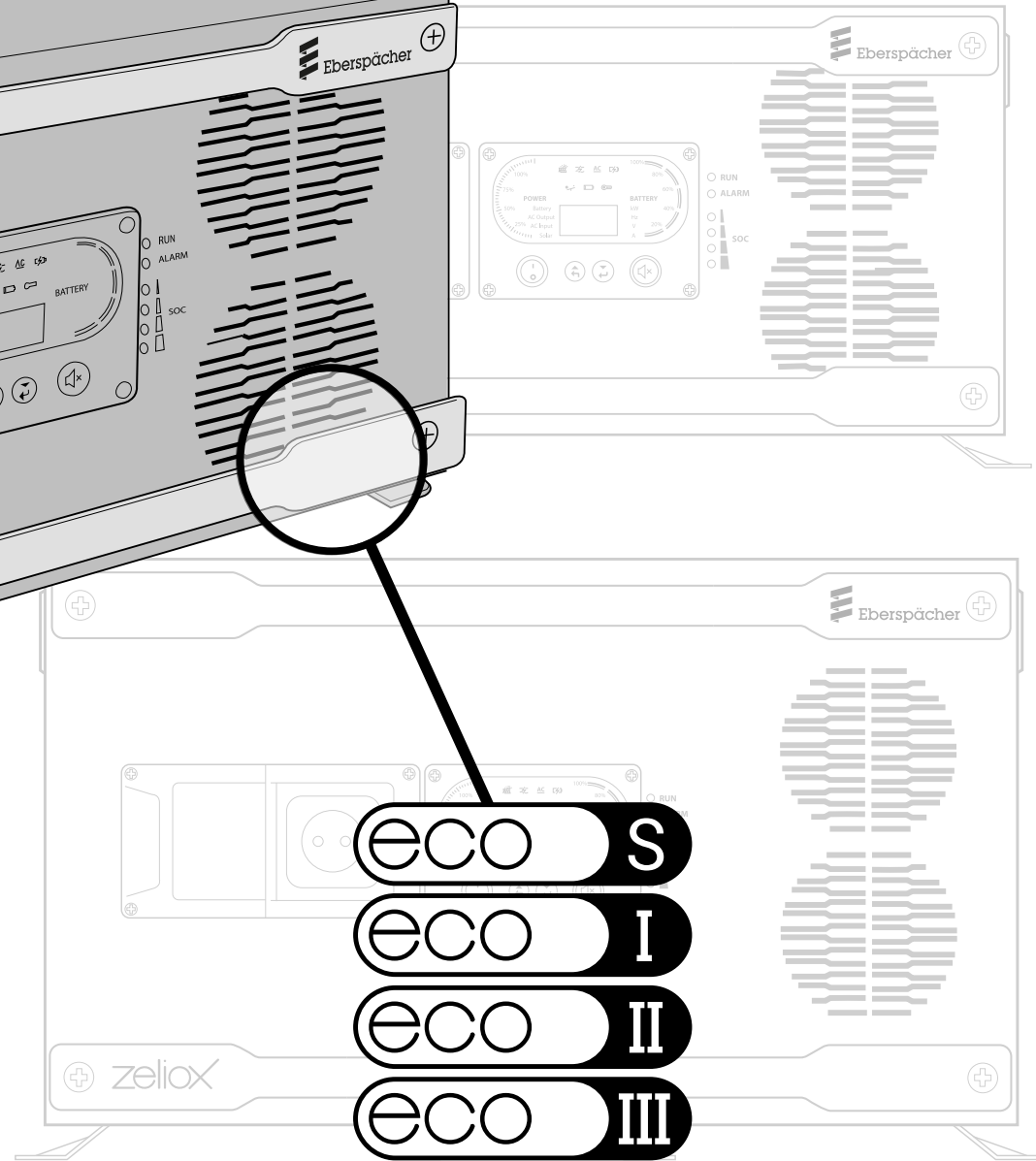

1. Use of the ECO

The Zeliox ECO is taking care of **collecting, storing** and **distributing** power, all packed into one device. **Simply** plug your tools and appliances into the front power socket or optionally, into other sockets in your vehicle. The **maximum available capacity** is depending on the ECO type (see chapter 6 for more details).

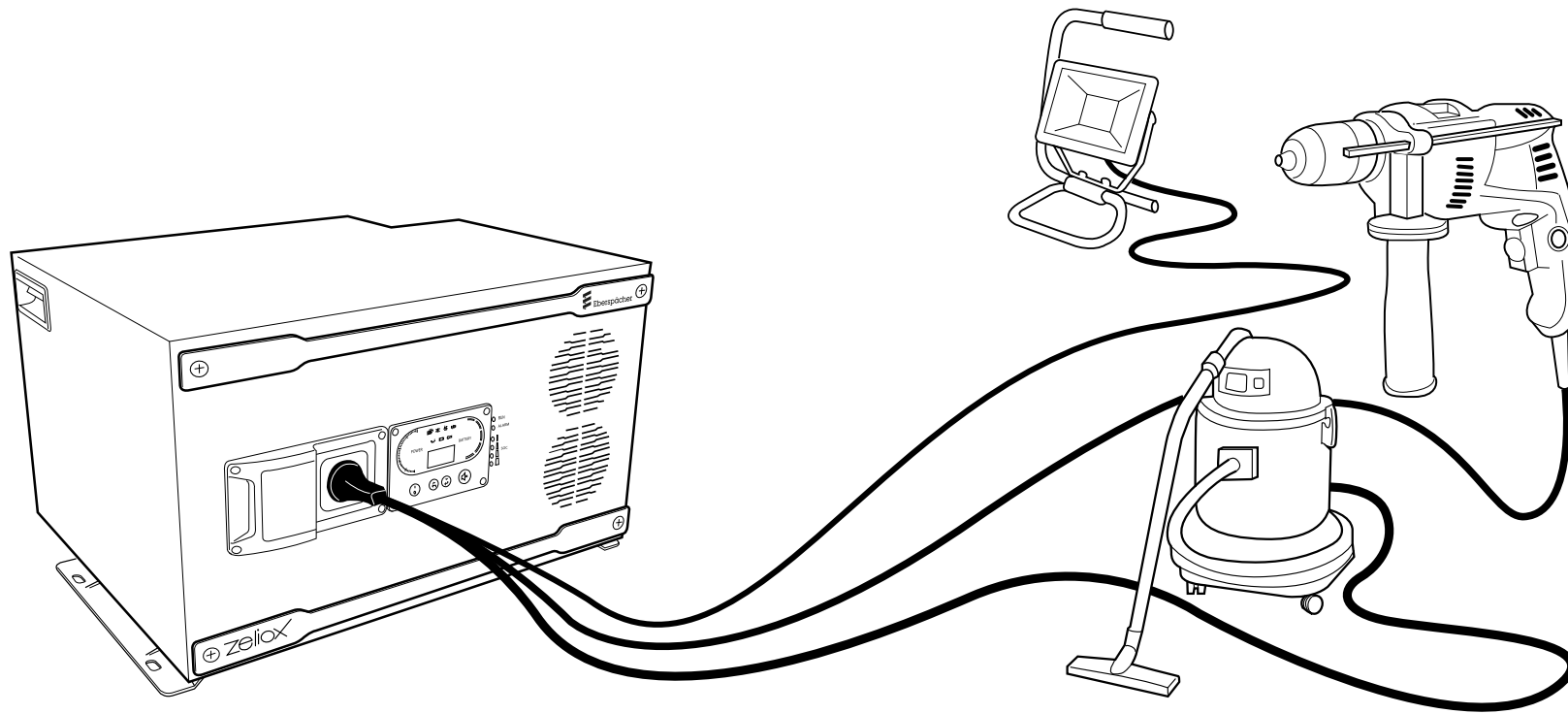

2. Keep your Zeliox updated with the Zeliox-App

The app gives you **real-time information** on battery status, remaining battery time, charging details, current consumption, (dis-)charging history, battery lifetime and alarm events. You also can use the app to keep your ECO **up to date** with **new developed features** and the latest **firmware**.

Make sure that your **Bluetooth** is switched on.



Zeliox

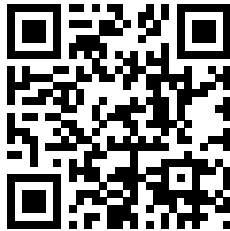

Service portal

You can find us in Google Play store app or Apple store.

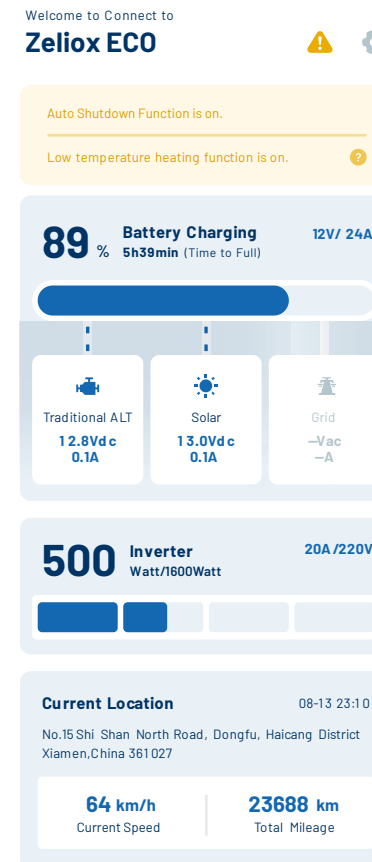

Menu / Alarms

Events / Functions

Current battery status

Current charging status

Current consumption

3. How to operate your Zeliox ECO?

| Switch RCD ON (upwards) ① | | |
|--|------------------------------------|--|
| Front ON/OFF | Remote Switch (optional) | Grid Charging (only ECO I, II, III) |
| | | |
| Switch ON ② | Push ON ③ | Auto ON ④ |
| | | Should your home grid not support 16A, then switch the Zeliox ON by hand. |
| Use front power socket ⑤ | | |
| Or use optional power sockets in the vehicle ⑥ | | |
| Switch OFF (if not in use) | Push OFF (if not in use) | Auto OFF |
| Warning: use the same switch (front or remote) to switch ON or OFF. Do not mix both switches. | | |

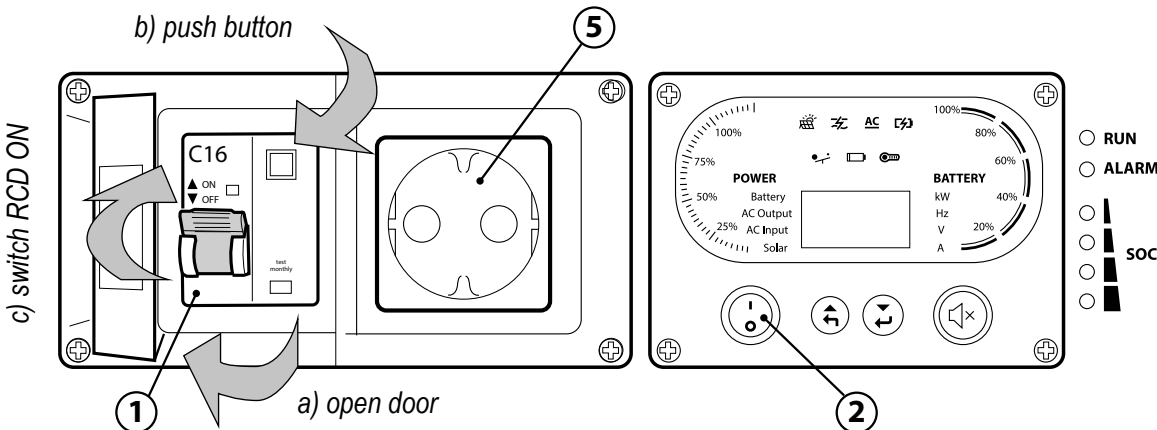
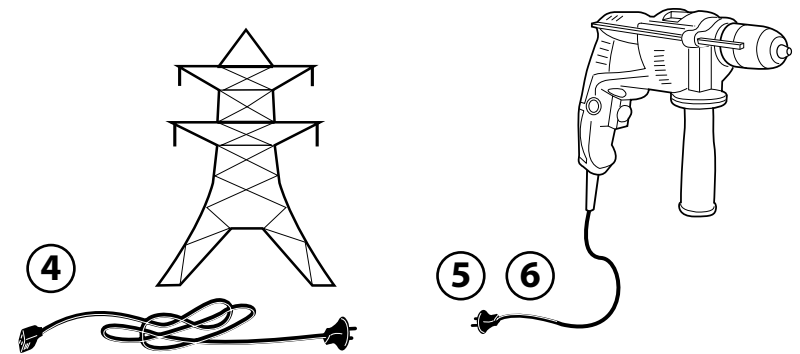
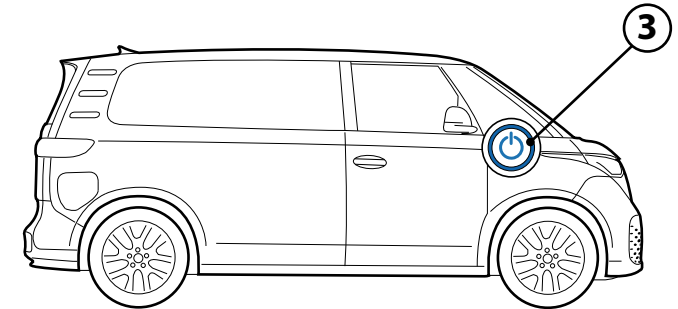

4. Explanation of the display

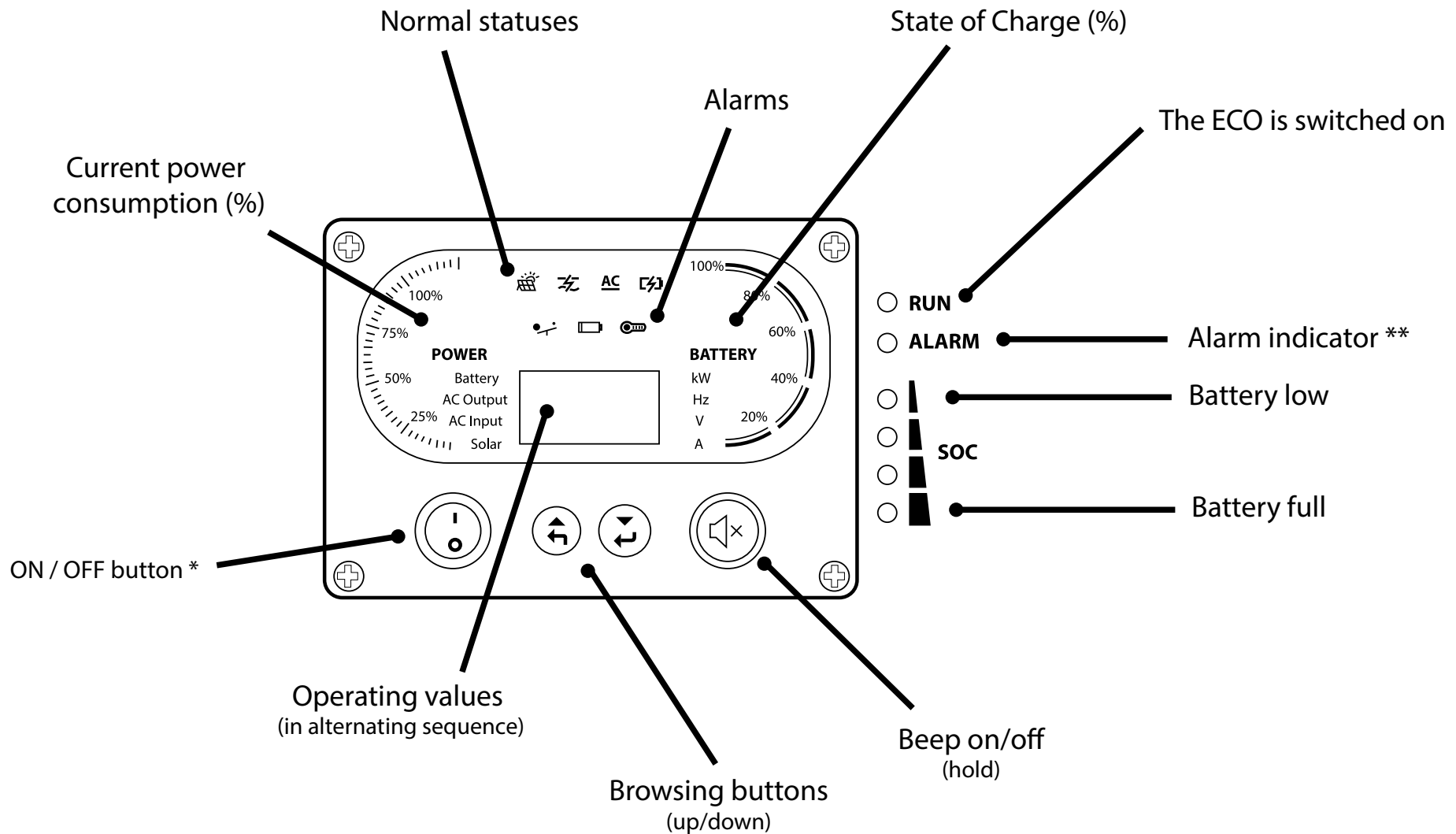

* See chapter 3 for combination with optional switch

** Consult user manual for detailed information

5. How does your Zeliox ECO charge?

This will run automatically and the charging options are shown below.
The Zeliox App (see chapter 2) gives you detailed information on the charging.

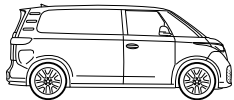

Drive charge

Remark: Electric vehicles have a limited charging speed for accessories and is depending on vehicle make and type. PLEASE NOTE: During charging, the 12V output is activated and any connected loads will be powered.



Grid charge *(only ECO I, II, III)*

Remark: When connected to the grid, the 230V inverter is switched off and a direct bypass is active. The RCD switch will protection against electrical faults. PLEASE NOTE: During charging, the 12V and 230V outputs are activated and any connected loads will be powered.

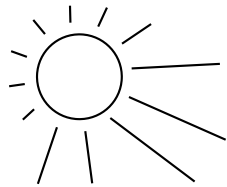

Solar charge *(option)*

Remark: To harvest sun energy, optional solar panels and a MPPT-converter needs to be installed. Ask your installer for Zeliox approved products, for the highest efficiency. Charging speeds may vary, depending on the intensity of the sunlight. PLEASE NOTE: During charging, the 12V output is activated and any connected loads will be powered.

Important: If your Zeliox ECO is switched off, the **charging** process of the battery will run in the background. Charging will activate the **display** and power the **12V output**. Additionally if you charge from the grid (only ECO I, II, III), the **230V outputs** are activated. Keep in mind that any **loads** connected to these outputs, will be **powered** during the charging process!

The display will deactivate automatically when the charging process is finalized.

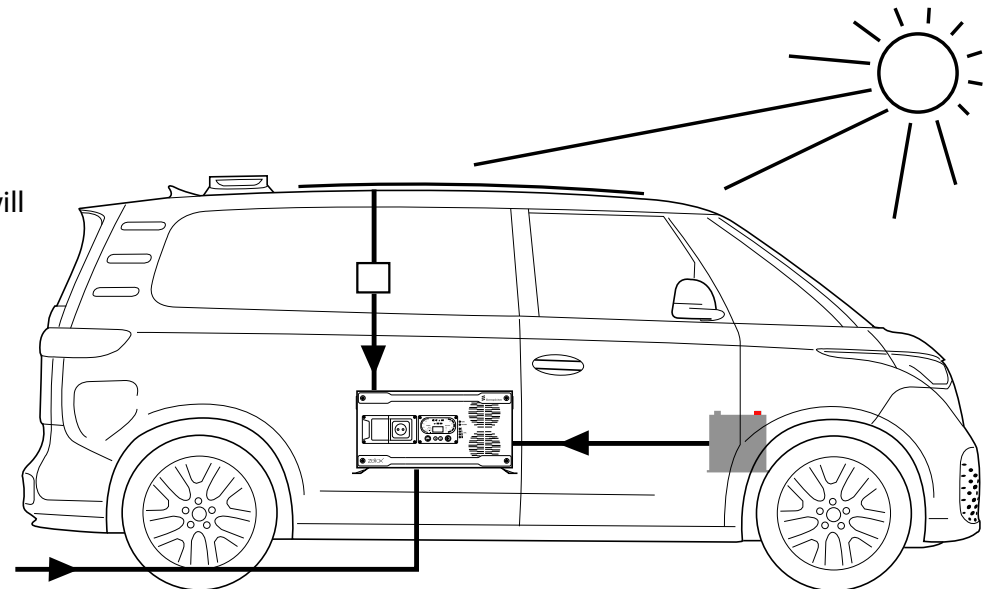
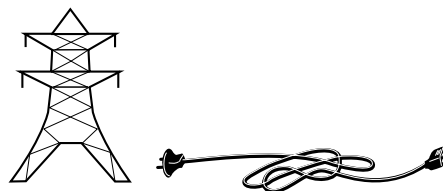

6. Zeliox ECO capacity and charging times*

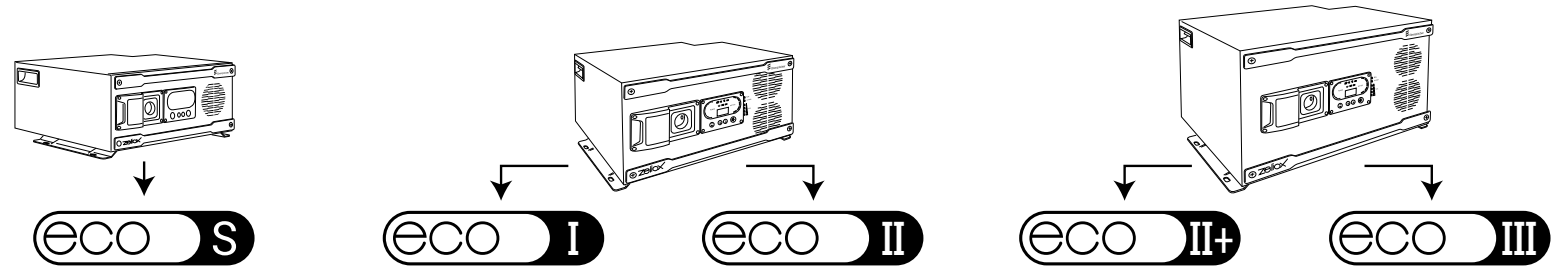

| | | 1000 Watt | 1600 Watt | 2000 Watt | 2000 Watt | 3000 Watt |
|-------------------------|-----------------------|-----------------|-------------------|-------------------|-------------------|-------------------|
| Power 230V | | 1000 Watt | 1600 Watt | 2000 Watt | 2000 Watt | 3000 Watt |
| Battery capacity | | 600Wh / 50Ah | 1300Wh / 100Ah | 1300Wh / 100Ah | 2600Wh / 200Ah | 2600Wh / 200Ah |
| Car ** | <i>charging power</i> | 426W | 426W | 426W | 852W | 852W |
| | <i>charging time</i> | 1h30m | 3h | 3h | 3h | 3h |
| Grid | <i>charging power</i> | N/A | 852W | 852W | 1420W | 1704W |
| | <i>charging time</i> | N/A | 1h30m | 1h30m | 1h45m | 1h30m |
| Solar ** | <i>charging power</i> | 200Wp | 200Wp | 200Wp | 400Wp | 400Wp |
| | <i>charging time</i> | 3h15m | 6h25m | 6h25m | 6h24m | 6h24m |

* Exclusive external batteries

** See remarks chapter 5

7. What does the Zeliox ECO Insulation Guard do?

The Zeliox ECO is standard equipped with an insulation guard. When working in a mobile environment you are not earth grounded and thus not protected in case of short circuit due to moisture or cable damage. The Zeliox insulation guard protects you against this risk.

Risk

- In a vehicle you are not earth grounded!
- In the event of a short circuit a RCD (circuit breaker) will not be activated.
- The person will get an electrical shock or could get electrocuted.

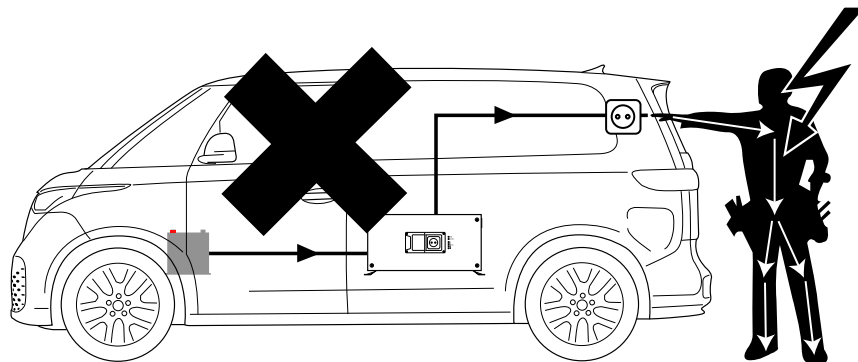

Standard

Working of an insulation guard

- It detects short circuits due to moisture or touching bare wires.
- It automatically shuts down the Zeliox.
- In accordance with DIN VDE 0701/0702 and NEN 1010.

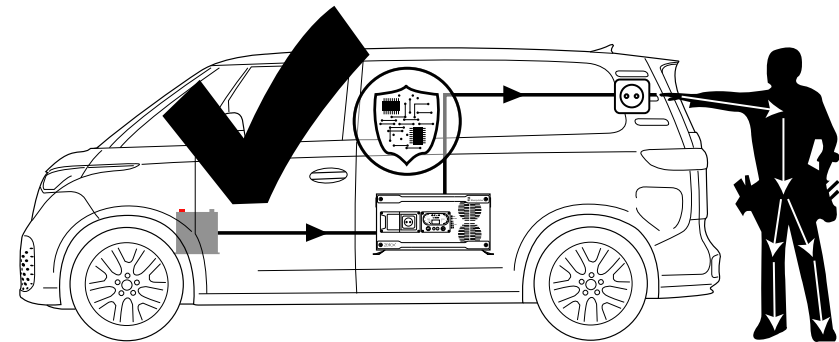

Zeliox ECO

8. What does the Zeliiox Heat Pack do?

The built-in Li-ion battery in the Zeliiox ECO has a special built-in heating pack. Operating Li-ion batteries in low temperatures, could shorten the battery life significantly.

Below 5° Celsius, our heat pack will automatically switch on (if there is an external power source connected). The charging process will start, after it has heated up the battery cells sufficiently.

In frequent low temperature environments, we recommend connecting the Zeliiox to the grid as much as possible and switch it off if not in use.

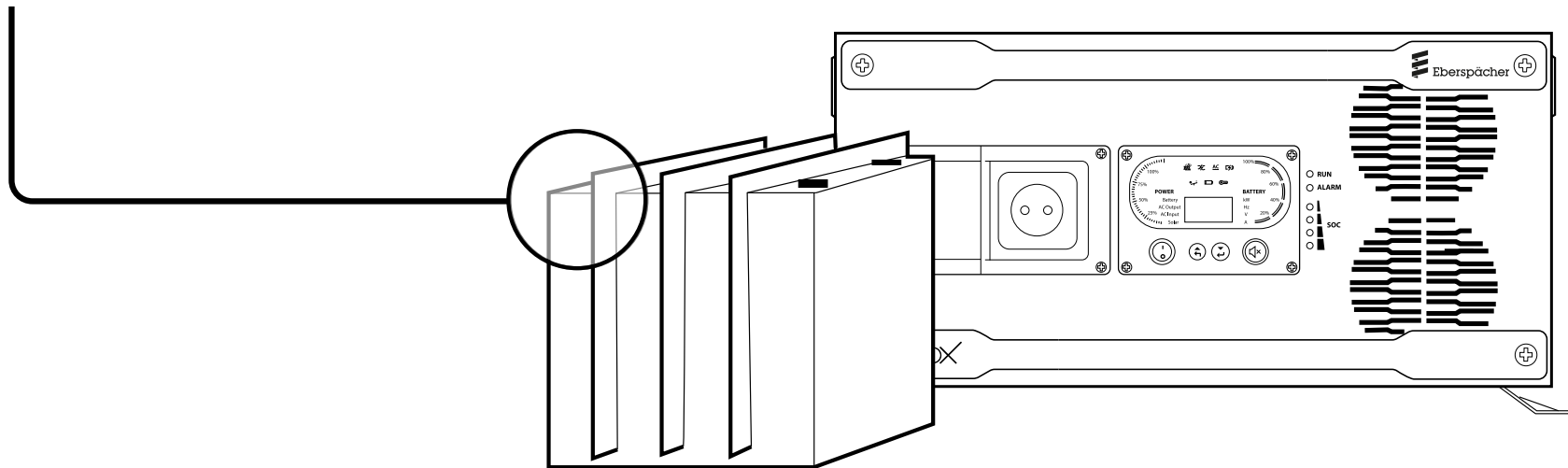

9. Prevent overheating!

Make sure that the front and rear ventilation openings are clear. Should the Zeliox become overheated, switch the device off and let it cool down.

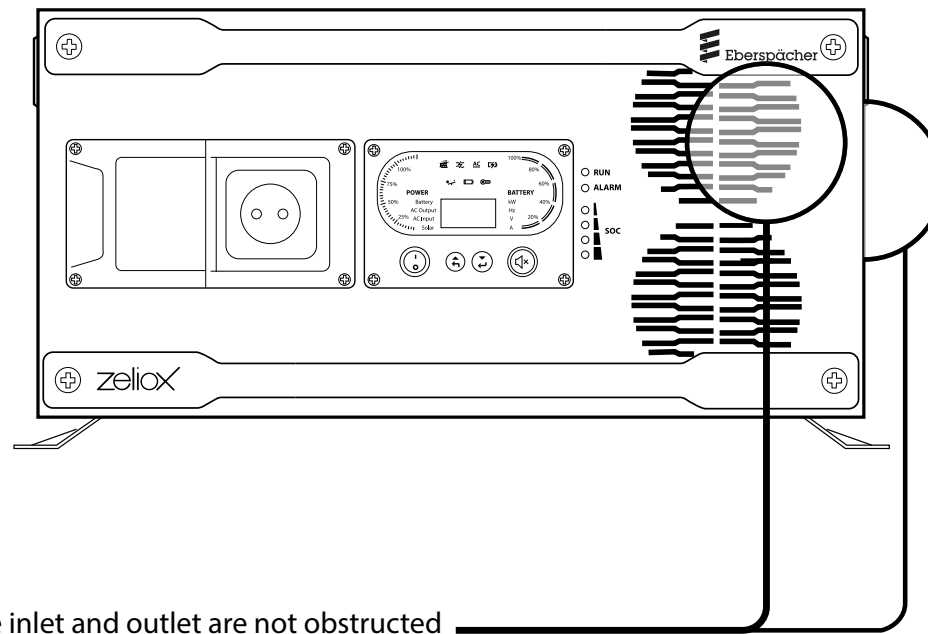

Make sure the inlet and outlet are not obstructed

10. In case of an Alarm

First look into the Zeliox App to see what happend.

- Icon yellow warning triangle: Clicking will show the most recent alarm message.
- Icon Gear: Click and select "Events" for the full message history.

Still don't know what to do? Contact your installer or dealer.

Please note: when contacting your installer be sure you have the **s/n serial number** of the Zeliox ECO.



only with model B

with model A and B

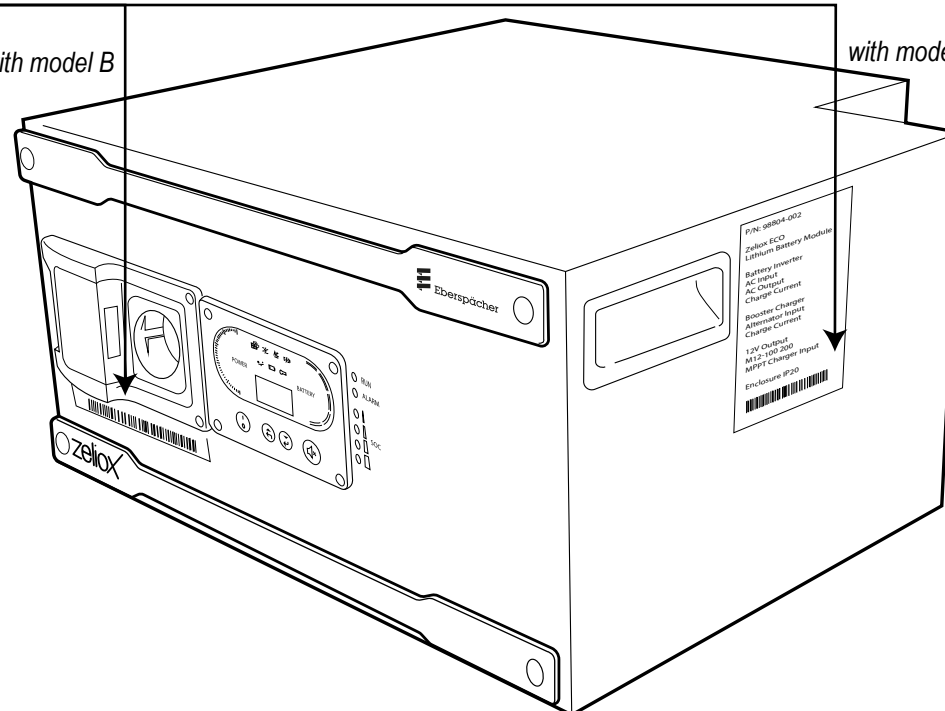

11. Disposal or recycle

Disposal and recycling of lithium batteries should comply with local, state, and federal laws and regulations. Mixed treatment with other (industrial) waste is prohibited.



Service portal



For more specifications see www.eberspaecher-zeliox.com

Eberspächer Zeliox B.V.
Spaarpot 13
5667 KV Geldrop
The Netherlands